

Handling Instructions for Incremental Encoders

Summary

This application note is to assist in the correct handling of drives with **incremental encoders** in order to prevent early product failure and issues during operation.

Main aspects are:

- compatibility to other components of a drive system especially controllers
- ESD-conform handling
- correct mounting and connecting of drives with incremental encoders
- correct selection and use of extension cables in order to avoid EMI issues

Applies To

FAULHABER incremental encoders

- IEH2-4096, IEH3-4096, IEH3-4096 L
- IE2-400, IE2-1024
- IE3-1024, IE3-1024 L
- IER3-10000, IERS3-500, IER3-10000 L, IERS3-500 L
- IEF3-4096, IEF3-4096 L
- IEP3-4096

Description

1. Compatibility of encoders to other drive components

During product selection the entire drive system should already be considered. One advantage of the drive components offered by FAULHABER is that they are perfectly matched to one another.

With focus on encoders the mechanical interface between motor and encoder as well as the electrical interface between controller and encoder are relevant:

- Available combinations of encoder families are noted in the datasheets of the motors.
- For the IER3-10000 (L) the max. resolution depends on the selected motor. The assignment between motor series and available resolution can be found in the IER3 data sheet.
- Extension cables and adapter pcbs for connecting FAULHABER encoders to motion controllers out of the MC V3.0 portfolio are listed in the accessories manual 7000.05059. Manuals can be downloaded on the FAULHABER homepage.

 **If motion controllers from other manufacturers are used, the compatibility of the incremental interface should be checked carefully. Please note:**

- The signals' high- and low-voltage levels have to fit to the controller's inputs. It should be ensured that the load at the encoder channels stays below the max. output current specified in the encoder datasheets.
- If longer cables are necessary, use a controller and encoder with a differential line driver interface based on the RS422-standard.
- Use a controller with quadrature count evaluation of the incremental signals in order to be more robust against signal disturbances and noise.
- The max. signal frequency of the encoder must be considered and must stay below the max. permissible input frequency of the respective controller inputs in order to prevent miscounting. The relevant parameter to determine the max. signal frequency of the encoder is the minimum edge spacing.

For further information about the incremental interface and the calculation of the max. signal frequency see application note 144.

2. ESD-conform handling of encoder products

When handling electrical devices it is important to avoid electrostatic discharge (ESD). ESD can be caused for example by friction between two non conducting materials. ESD pulses can reach several kV and might damage electronics devices even if not immediately noticed.

FAULHABER encoders are characterized by their high degree of miniaturization. This often limits the option for additional ESD protection components. If space is available – like it is for the IE3-, IER3-, IEF3- and IEP3-encoder families – so called *diode arrays* are implemented on the sensor pcb, which increase the robustness against ESD at all pins.

⚠ Nevertheless: From unpacking to mounting – all encoders should always be handled ESD-conform in order to exclude damages. Take the following measures into account:



Figure 2: ESD-conform handling of encoders

- a) **ESD-conform packaging:** FAULHABER encoders are packed up in antistatic shielding bags. After unpacking them, antistatic shielding bags or ESD-trays should still be used for further transport.
- b) **ESD-conform work clothes:** Wear conductive work clothes and an earthed wristband
- c) **ESD-conform workplace:** The workplace should be equipped with a conductive ESD-mat and a connection to earth for the wristband

3. Mounting the motor – mechanical aspects

In general, the front flange of the motor should be secured to a suitable surface with fastening screws (compare Figure 3). For a detailed instruction including a specified tightening torque and the permissible length of the screws see also for incremental encoders the manual 7000.05070, chapter 4.1.1 and 4.1.2.

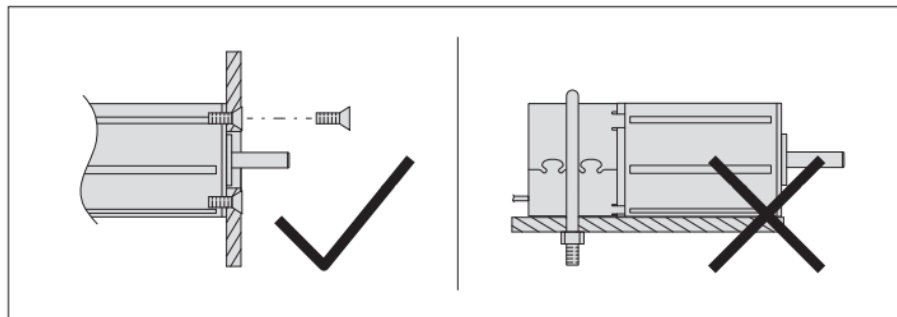

Figure 3: Mounting example - 22xxBX4 IE(R)3 series

Furthermore, make sure that the encoder's connection cable is not stressed mechanically– see manual 7000.05070, chapter 4.1.3.¹

CAUTION

The drive can become very hot during operation. Place a guard against contact and warning notice in the immediate proximity of the drive (compare Figure 4).



Figure 4: Suitable warning sign acc. to DIN EN ISO 7010

4. Connecting the encoder – pin assignment and electrical parameters

The pin assignment and further electrical parameters which are relevant to connect an encoder can be found in the respective product data sheets.

 Assure especially, that **the power supply voltage stays in the specified range** under all circumstances. **Even short-term high voltage peaks can damage the electronics.** Therefore consider the following points when connecting the encoder:

¹ The given force values in manual 7000.05070 are only valid for the IE3-and IER3-encoder series

- Act according to the measures given in chapter 2 in order to prevent ESD-damages
- Take care, that stripped cable ends don't touch nearby conductive objects
- Only connect the encoder to a controller when power supply is switched off. Hot plugging is not supported!
- Check, that the cable is connected correctly before power supply is switched on. A polarity reversal as well as shortcuts between the outputs destroy the electronics.

 **DANGER**

Incorrect handling and installation can cause a motor with encoder to perform uncontrolled movements.

A damaged drive can unexpectedly start, stop or jam. Depending on the use of the motor-encoder combination, this can lead to severe or fatal injury. Observe the following safety information:

- Do not start up a drive system with a defective or damaged motor-encoder combination
- Appropriately mark a defective or damaged motor-encoder combination
- Make no changes (modifications, repairs) to the motor-encoder combination
- Have loose or defective connections immediately replaced by an electrician
- After replacing a defective or damaged motor-encoder combination, test and document the correct function

5. Extension cables, cable routing and shield connection

Most FAULHABER encoders have a flat-ribbon cable with a length of 150mm to 200mm.

In applications with a greater distance between controller and drive unit suitable extension cables must be used. Especially when connecting over a distance of several meters the cable configuration and routing as well as the shield connection must be considered carefully.

This will improve the electromagnetic immunity of the encoder interface and allow for a trouble-free operation.

Important in this context is:

- For a length of more than 0.5 m a line driver interface is recommended. In this case an extension cable with twisted pairs for the complementary signals should be used.
- The encoder cable – signals and supply - must always be routed separated from the motor phases or other power lines.
 - A separate shield braid is required.
 - The distance between signal and power lines should be as large as possible.
- Controller and motor housing must be connected to a common earth. If mounted at different metallic structure of the device or machine, ensure suitable high frequency connection between all parts. The shield braid of the used cables must be flatly connected to earth on both sides, too.

For suitable extension cables between controllers and encoders see the accessories manual 7000.05059.

 **WARNING**

The motor-encoder combination can cause high-frequency interference which can affect the function of electronic implants and other electronic devices.

- Take appropriate interference suppression measures, particularly during use in residential environments
- Observe the notices for EMC-compliant setup given in the manuals 7000.05057 and 7000.05070, chapter 4.3 as well as in the application note 187.

Legal notices

Copyrights. All rights reserved. This Application Note and parts thereof may in particular not be copied, reproduced, saved (e.g. in an information system), altered or processed in any way irrespective of the purpose without the express prior written consent of Dr. Fritz Faulhaber & Co. KG.

Industrial property rights. In publishing, handing over/dispatching or otherwise making available this Application Note Dr. Fritz Faulhaber & Co. KG does not expressly or implicitly grant any rights in industrial property rights nor does it transfer rights of use or other rights in such industrial property rights. This applies in particular to industrial property rights on which the applications and/or functions of this Application Note are directly or indirectly based or with which they are connected.

No part of contract; non-binding character of the Application Note. The Application Note is not a constituent part of contracts concluded by Dr. Fritz Faulhaber & Co. KG and the content of the Application Note does not constitute any contractual quality statement for products, unless expressly set out otherwise in the respective contracts. The Application Note is a non-binding description of a possible application. In particular Dr. Fritz Faulhaber & Co. KG does not warrant or guarantee and also makes no representation that the processes and functions illustrated in the Application Note can always be executed and implemented as described and that they can be used in other contexts and environments with the same result without additional tests or modifications. The customer and any user must inform themselves in each case before concluding a contract concerning a product whether the processes and functions are applicable and can be implemented in their scope and environment.

No liability. Owing to the non-binding character of the Application Note Dr. Fritz Faulhaber & Co. KG will not accept any liability for losses arising from its application by customers and other users. In particular, this Application Note and its use cannot give rise to any claims based on infringements of industrial property rights of third parties, due to defects or other problems as against Dr. Fritz Faulhaber GmbH & Co. KG.

Amendments to the Application Note. Dr. Fritz Faulhaber & Co. KG reserves the right to amend Application Notes. The current version of this Application Note may be obtained from Dr. Fritz Faulhaber & Co. KG by calling +49 7031 638 345 or sending an e-mail to mcsupport@faulhaber.de.