

Brushless DC-Flat Motors

External rotor technology, without housing

41 mNm
30 W

Series 3216 ... BXT R

Values at 22°C and nominal voltage	3216 W	009 BXT R	012 BXT R	024 BXT R	
1 Nominal voltage	U_N	9	12	24	V
2 Terminal resistance, phase-phase	R	0,55	0,88	3,26	Ω
3 Efficiency, max.	η_{max}	82	83	82	%
4 No-load speed	n_0	6 020	6 240	6 200	min ⁻¹
5 No-load current, typ. (with shaft \varnothing 4 mm)	I_0	0,179	0,129	0,084	A
6 Starting torque	M_A	225	245	263	mNm
7 Speed constant	k_n	691	530	267	min ⁻¹ /V
8 Back-EMF constant	k_E	1,45	1,89	3,75	mV/min ⁻¹
9 Torque constant	k_M	13,8	18	35,8	mNm/A
10 Current constant	k_I	0,0724	0,0555	0,0279	A/mNm
11 Slope of n-M curve	$\Delta n/\Delta M$	27,5	25,9	24,3	min ⁻¹ /mNm
12 Terminal inductance, phase-phase	L	191	331	1 290	μ H
13 Mechanical time constant	τ_m	5,28	4,97	4,66	ms
14 Rotor inertia	J	18,3	18,3	18,3	gcm ²
15 Angular acceleration	α_{max}	123	134	144	$\cdot 10^3$ rad/s ²
16 Operating temperature range:					
– motor		-40 ... +100			°C
– winding, max. permissible		+125			°C
17 Shaft bearings		ball bearings, preloaded			
18 Shaft load max.:					
– with shaft diameter		4			mm
– radial at 3 000 min ⁻¹ (5 mm from mounting flange)		15			N
– axial at 3 000 min ⁻¹ (push / pull)		3			N
– axial at standstill (push / pull)		50			N
19 Shaft play:					
– radial		≤ 0,015			mm
– axial		= 0			mm
20 Mass		57,9			g
21 Direction of rotation		electronically reversible			
22 Speed up to	n_{max}	10 000			min ⁻¹
23 Number of pole pairs		7			
24 Hall sensors		digital			
25 Magnet material		NdFeB			
Rated values for continuous operation					
26 Rated torque	M_N	39,5	40	41	mNm
27 Rated current (thermal limit)	I_N	2,87	2,28	1,17	A
28 Rated speed	n_N	3 320	3 750	4 150	min ⁻¹
29 Rated slope of n-M curve	$\Delta n/\Delta M$	68,4	62,3	50	min ⁻¹ /mNm

Note: Rated values are measured at nominal voltage and 22°C ambient temperature.

Note:

The display shows the range of possible operation points of the drives at a given ambient temperature of 22°C.

The diagram indicates the recommended speed in relation to the available torque at the output shaft.

It includes the assembly on a plastic- as well as on a metal flange (assembly method: IM B 5).

The nominal voltage linear slope describes the maximal achievable operating points at nominal voltage. Any points of operation above this linear slope will require a supply voltage $U_{mot} > U_N$.

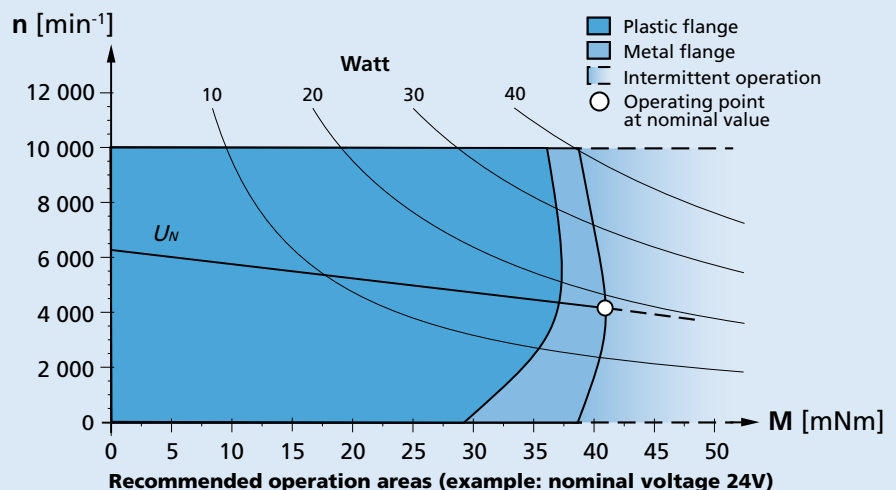

Dimensional drawing

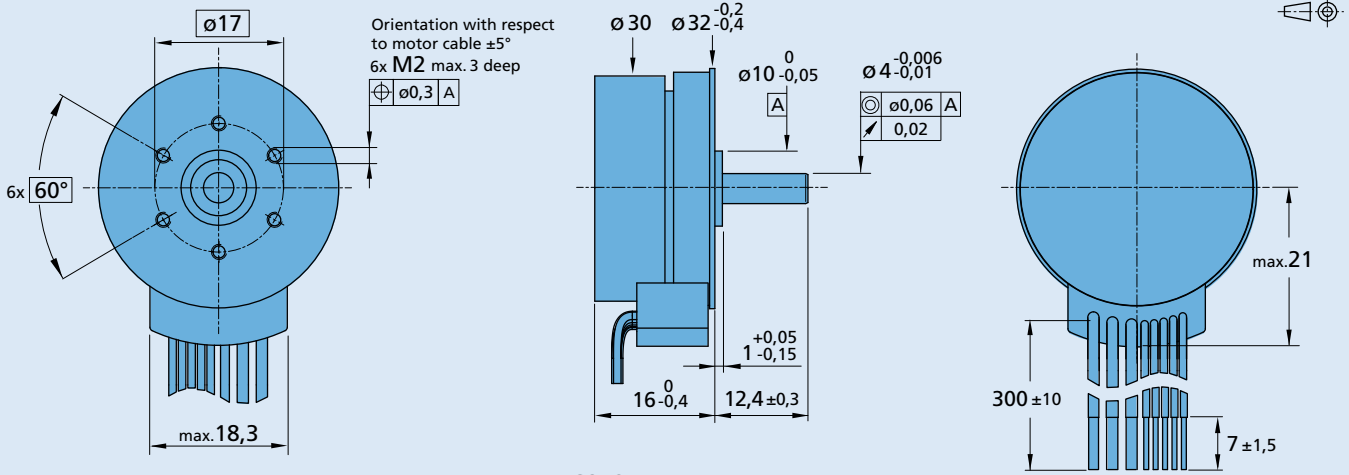

Option, cable and connection information

Example product designation: **3216W012BXTR-3830**

Option	Type	Description	Connection	
			No.	Function / Colour
3830	Connector 	Standard cable with connector MOLEX Microfit 3.0, 43025-0800, recommended mating connector 43020-0800	1	Phase C yellow
			2	Phase B orange
			3	Phase A brown
			4	GND black
			5	U _{DD} (+5V) red
			6	Hall sensor C grey
			7	Hall sensor B blue
			8	Hall sensor A green
			Standard cable Single wires, material PVC, AWG 20, Phase A/B/C AWG 26, Hall A/B/C, U _{DD} , GND	

Product combination

Precision Gearheads / Lead Screws	Encoders	Drive Electronics	Cables / Accessories
22GPT 22GPT HT 26A 26/1R 32GPT 32GPT HT 32/3R 22L ... ML 22L ... SB 22L ... PB 32L ... TL 32L ... ML 32L ... SB 32L ... PB		SC 2402 P SC 2804 S	To view our large range of accessory parts, please refer to the "Accessories" chapter.